

*For more info about compatibility with other models
please see the sticker on the skid plate

JEEP WRANGLER JK (DIESEL)

No.: 2730.1/6 Engine block & gearbox
2731.1/6 Transfer case

Year: 2007-
Engine: 2.8
Transmission: MT

FITTING KIT

1. Bolt M10x30.....	7 pc
2. Bolt M10x40.....	1 pc
3. Washer 10.....	8 pc
4. Insert nut M10x100/50.....	1 pc
5. Left bracket.....	1 pc
6. Right bracket.....	1 pc
7. Bar 1.....	1 pc
8. Bar 2.....	1 pc

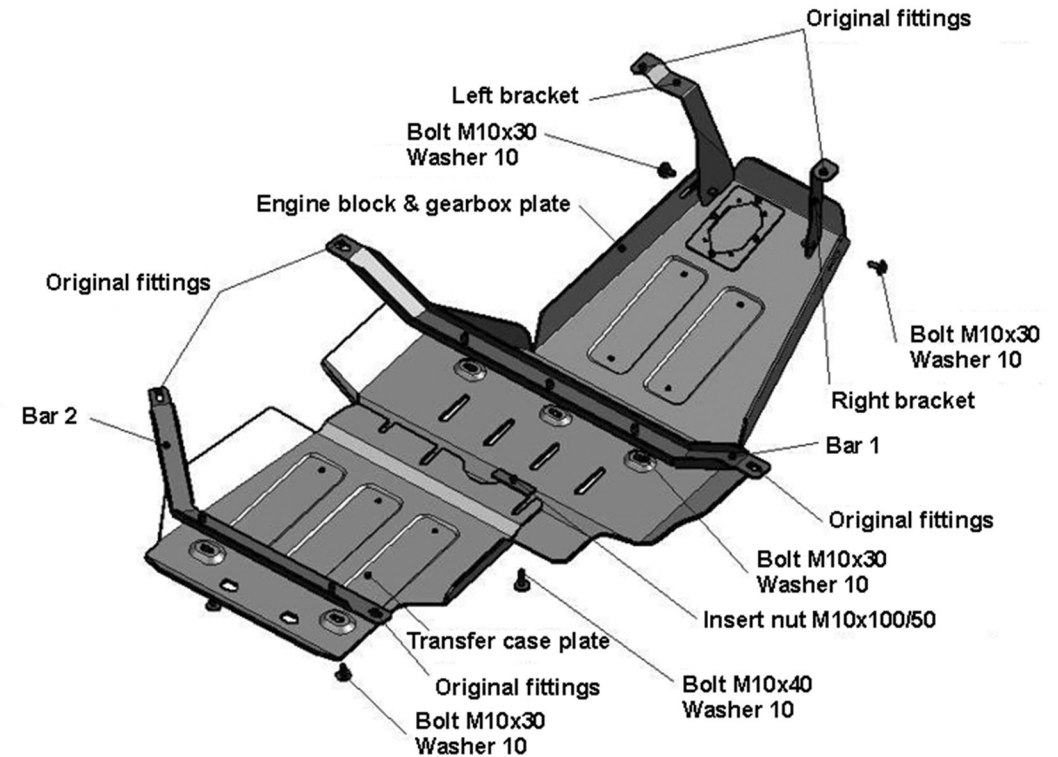

INSTALLATION INSTRUCTIONS

1. Remove original transfer case guard and original cross-bar.
2. Mount right and left brackets to supports of engine with original fittings.
3. Mount bar 1 to original threaded apertures of underframe with original fittings.
4. Mount bar 2 to original threaded apertures of underframe with original fittings.
5. Mount insert nut M10x100/50 above the aperture in underframe.
6. Fix engine block & gearbox plate to left and right brackets with bolts M10x30, then to bar 1 with bolts M10x30. Also fix it to underframe with original fittings; then fix the plate to mounted insert nut with bolts M10x30.
7. Place front end of transfer case plate under engine block & gearbox plate, then fix its rear end to bar 2 with bolts M10x30.
8. Tighten all screws (50 Nm for M10, 30 Nm for M8, 10 Nm for M6). Do not use pneumatic or power tools to tighten.



WWW.RIVAL4X4.COM