



INSTALLATION MANUAL

PRODUCT: RADIATOR SKID PLATE

APPLICATION: FORD RANGER (2022-Present)
FORD RANGER (USA) (2024-Present)
FORD RANGER PLUG-IN-HYBRID (2025-Present)
FORD EVEREST (2022-Present)
VOLKSWAGEN AMAROK (2023-Present)

PART NO: 2111.1884.1.3
2333.1884.1
2333.1884.1.6

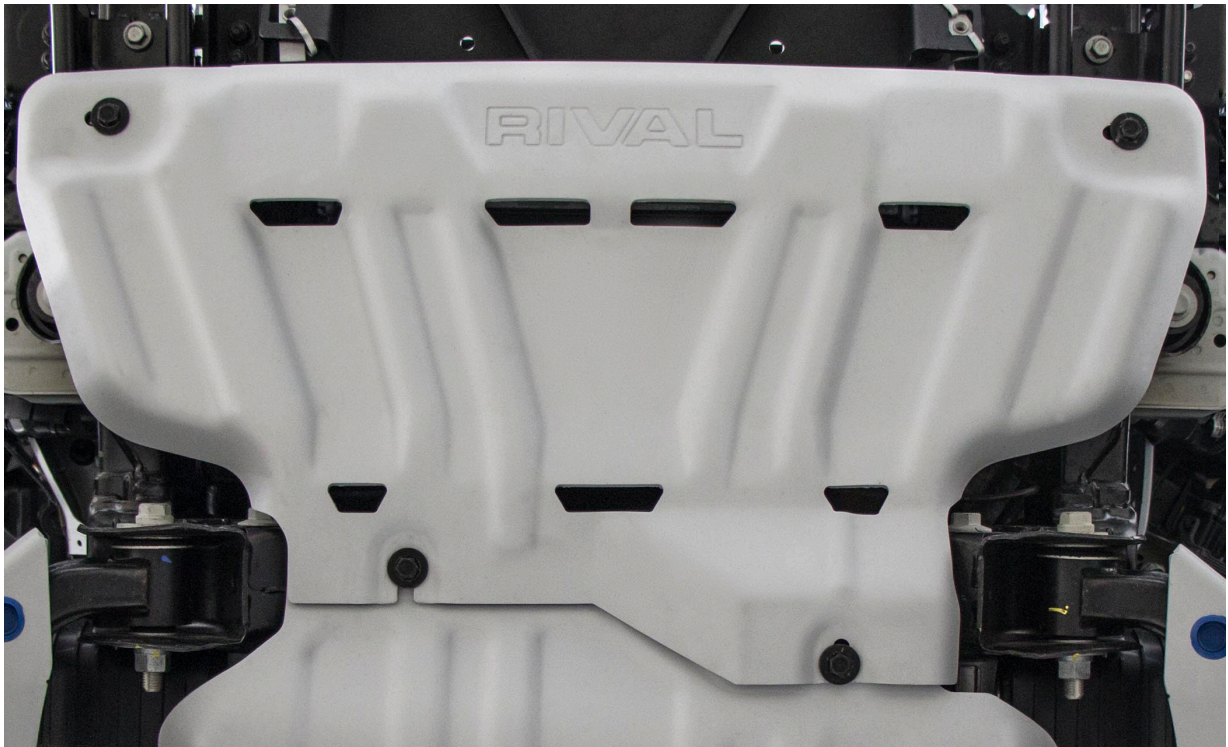

CAUTION!

To reduce the risk of serious injury or damage to property: Before you start installing and using this product, read the full instructions, pay special attention to the conditions of safe use and recommendations for installation! When installing or maintaining this product, it is necessary to use protective goggles. Check the integrity of the installed components and torque all hardware every 250 miles (400 kms). Discontinue use if there is any damage to the structure or fasteners!

NOTICE

Skid plates are supplemental protection. We cannot guarantee protection against all possible damage from impacts. When driving, be careful of objects and terrain that may damage sensitive parts of the vehicle.

RADIATOR SKID PLATE



Part number 2111.1884.1.3
2333.1884.1
2333.1884.1.6

Suited to vehicle: Ford Ranger* 2.0D, 3.0D; AT; 4WD (2022-Present)
Ford Ranger* (USA) 2.3; AT; RWD, 4WD (2024-Present)
Ford Ranger* Plug-In-Hybrid 2.3; AT; 4WD (2025-Present)
Ford Everest 2.0D; AT; 4WD (2022-Present)
Volkswagen Amarok* 2.0D, 3.0D; AT; 4WD (2023-Present)

Material: Steel / Aluminum

*Applicable to Double Cab



SAFETY NOTICE

- * The RIVAL skid plate is designed to complement the use and design of the specified vehicle under conditions underlined by the vehicle manufacturer.
- * While driving the vehicle at any speed, collision with another vehicle, animal or object must always be avoided.
- * Following any collision with another vehicle, animal or object, the RIVAL skid plate and the vehicle must be inspected by a specialized or suitably qualified vehicle technician for possible damage to the components and assemblies in order to confirm suitability for further use of the vehicle.
- * It is strongly recommended that you do not operate a vehicle with a damaged skid plate or its components. In the case of damage, please contact the nearest RIVAL dealer. A damaged vehicle or skid plate is extremely dangerous and should be avoided at all cost.
- * If applicable, we recommend using a funnel when changing the oil to prevent spills and ensure a clean process.

INSTALLATION NOTICE

- * The RIVAL skid plate must be mounted to the vehicle according to this installation manual.
- * Personal safety during the installation process must be adhered to at all times.
- * Do not install this skid plate on vehicle models other than those listed in this manual.
- * We recommend using blue threadlocker on all hardware.
- * Estimated time for installation: 1 hour.

REQUIRED TOOLS

- * Basic tool kit
- * Torque wrench

TORQUE SETTING

- * M10 - 47 Nm (34.7 lb/ft)

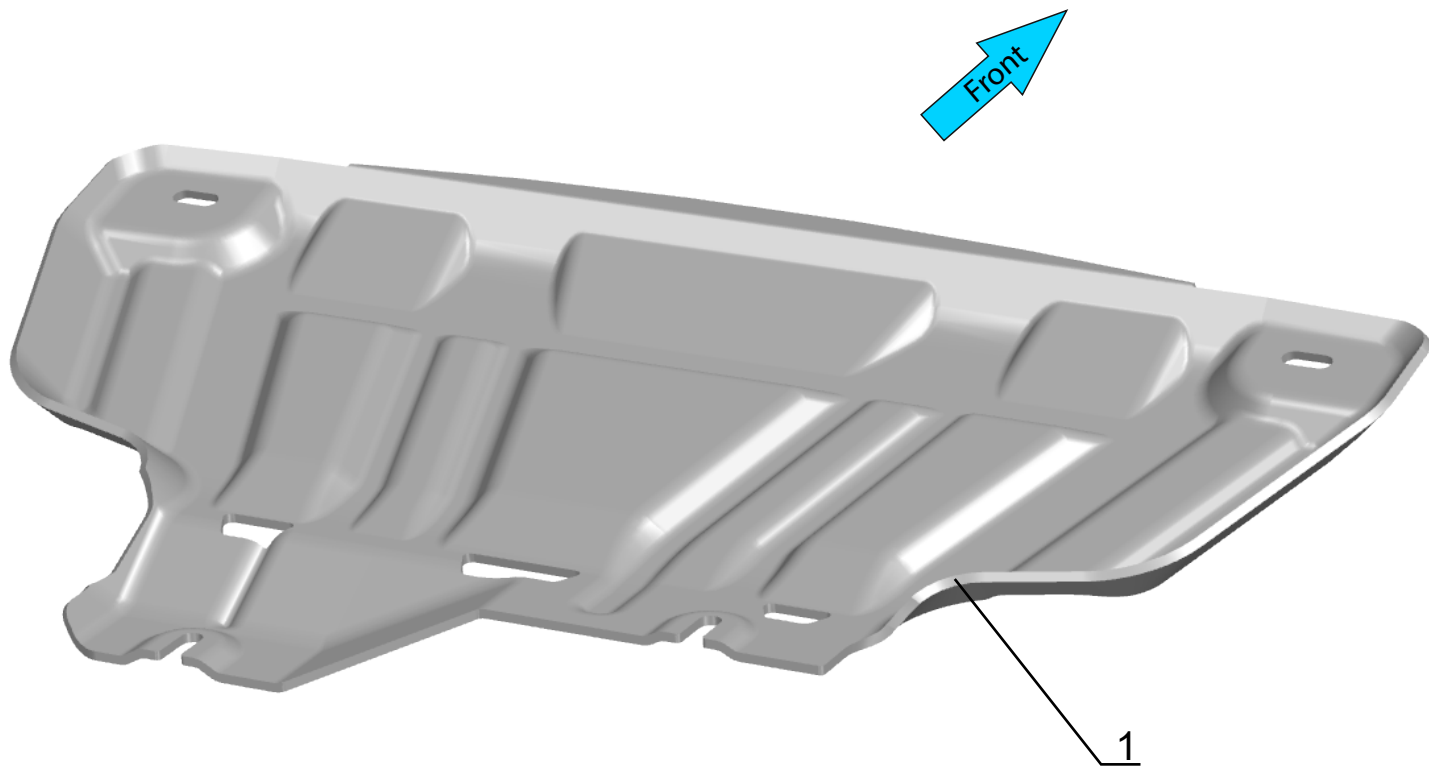

1. Radiator skid plate..... Qty 1

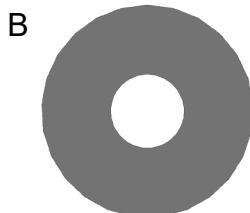

A. Bolt M10x1.5x30.....Qty 4
B. Washer M10.....Qty 4
C. Spacer 6 mm.....Qty 1

INSTALLATION PROCEDURE

RIVAL

*If equipped, remove factory or any aftermarket skid plates/splash guards that might interfere with installation.

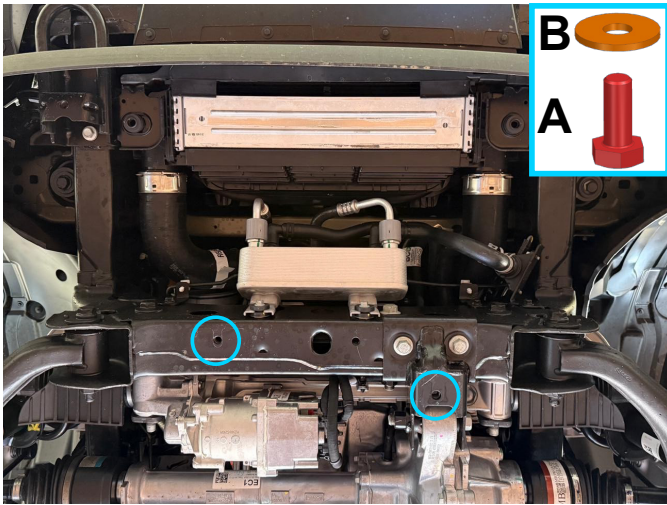

Fig. 1

1. Attach bolts M10x30 (item A) and washers 10 (item B), as shown in fig.1.

***For Ranger (USA) RWD:** add spacer (item C) for passenger side.

***Do not tighten yet.**

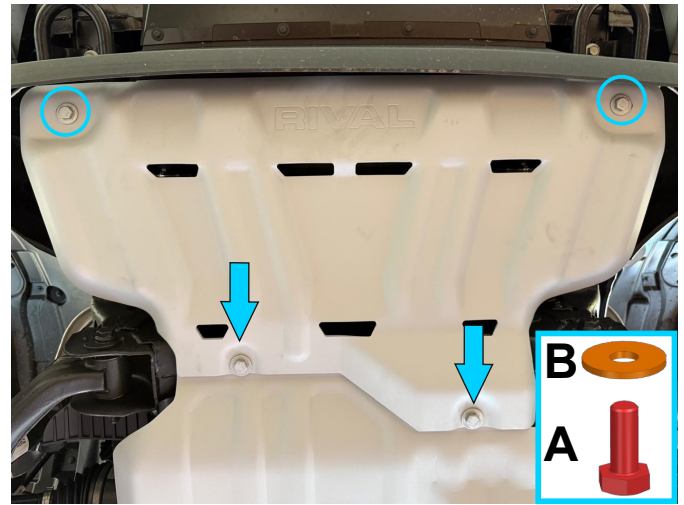

Fig. 2

2. Put radiator skid plate (item 1) on installed bolts M10x30 and washers 10 from step 2. Fix the front part of skid plate, using bolts M10x30 (item A) and washers 10 (item B), as shown in fig.2.

***Tighten hardware after that.**

Before operating a vehicle fitted with RIVAL Skid Plate:

- Make sure all fittings are tightened;
- Ensure the integrity of the structure and its components.