

*For more info about compatibility with other models
please see the sticker on the skid plate

JEEP WRANGLER JK

No.: 2723.1/6 Exhaust

Body: 2 door / 4 door

Year: 2007-

Engine: 3.6

Transmission: AT

FITTING KIT

1. Bolt M10x30.....	2 pc
2. Washer 10.....	2 pc
3. Insert nut M10x105/35.....	2 pc

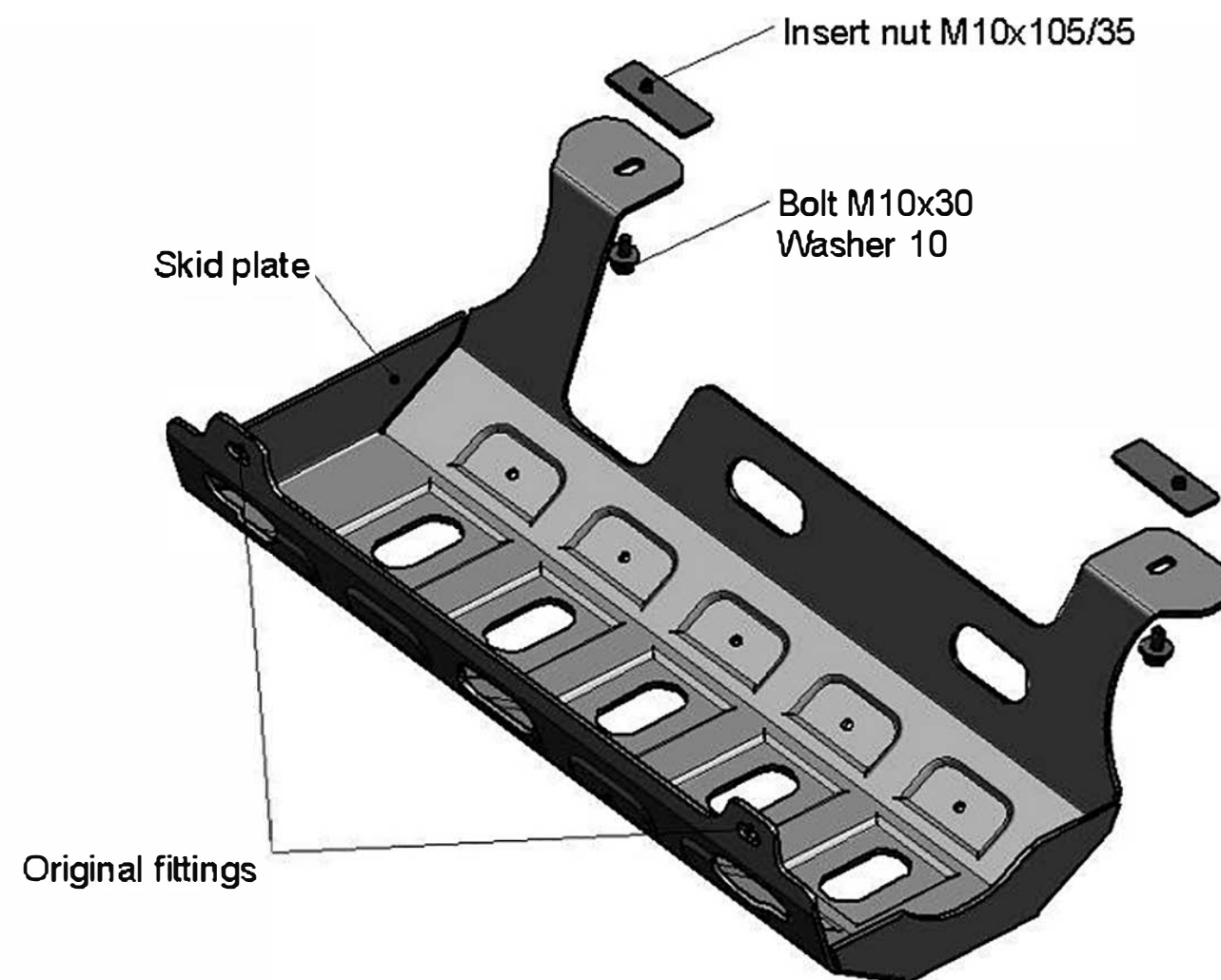

INSTALLATION INSTRUCTIONS

1. Screw 2 original bolts out from the inner side of rear bumper.
2. Mount insert nuts M10x105/35 into apertures in the rear end of vehicle body.
3. Fix front end of skid plate to mounted insert nuts, then fix its rear end to original threaded apertures with original fittings.
4. Tighten all screws (50 Nm for M10, 30 Nm for M8, 10 Nm for M6). Use of pneumatic tools is prohibited.



www.rivalauto.com