

*For more info about compatibility with other models
please see the sticker on the skid plate

MITSUBISHI L200 TRITON / PAJERO SPORT

No.: 4032.1 Radiator 4033.1 Engine
4034.1 Gearbox 4035.1 Transfer case

Year: 2006- / 2008-

Engine: All

Transmission: All

FITTING KIT

1. Bolt M8x35.....	6 pc
2. Bolt M10x35.....	9 pc
3. Washer 8.....	6 pc
4. Spring washer 8.....	6 pc
5. Washer 10.....	11 pc
6. Spring washer 10.....	9 pc
7. Insert nut M10x100/20.....	2 pc
8. Fix nut M8x70/20.....	2 pc
9. Insert nut M10.....	2 pc
10. Radiator bracket.....	1 pc
11. Bracket.....	1 pc
12. Bar.....	1 pc

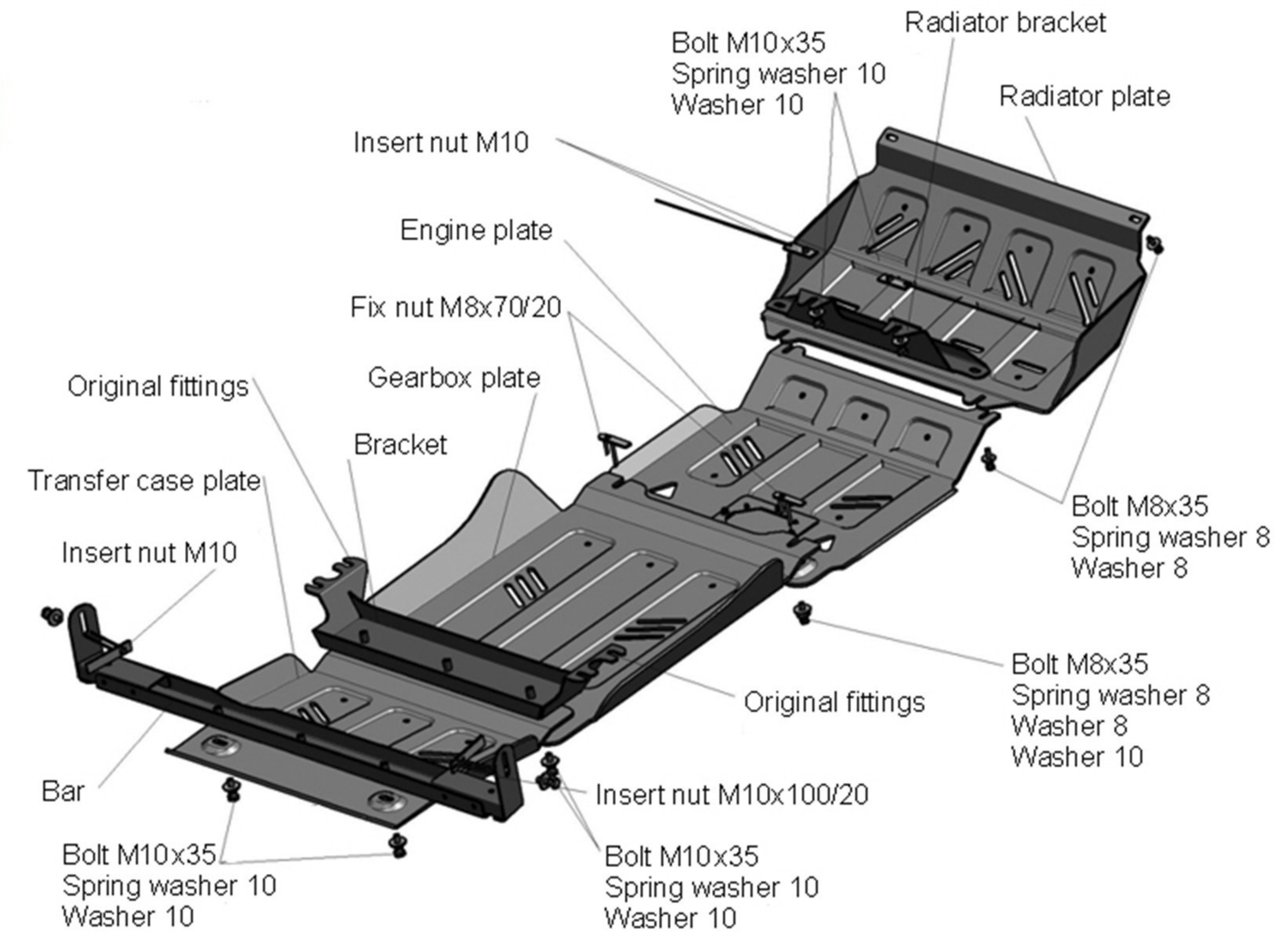

INSTALLATION INSTRUCTIONS

1. Remove original guards.
2. Place insert nuts M10 over original apertures in underframe, then screw bolts M10x35 into them.
3. Mount radiator bracket on installed bolts M10x35.
4. Fix front end of radiator plate to original fitting points with bolts M8x35, then fix its rear end to original fitting points through bracket with bolts M8x35.
5. Mount fix nuts M8x70/20 to original apertures in cross-bar.
6. Place front end of engine plate under radiator plate, then fix it to mounted fix nuts with bolts M8x35.
7. Screw 4 original bolts out of gearbox bar, then mount bracket and fix it with 4 original bolts.
8. Place front end of gearbox plate under engine plate, then fix its rear end to bracket with bolts M10x35.
9. Mount insert nuts M10x100/20 to apertures of underframe, then fix bar to them with bolts M10x35.
10. Place front end of transfer case plate under gearbox plate, then fix its rear end to mounted bar with bolts M10x35.
11. Tighten all screws (50 Nm for M10, 30 Nm for M8, 10 Nm for M6). Do not use pneumatic or power tools to tighten.



WWW.RIVAL4X4.COM